

- I** **Bruciatore policombustibile kerosene e gasolio/gas**
- GB** **Dual fuel kerosene and gas oil/gas burner**
- F** **Brûleur mixte kérosène et fioul/gaz**
- D** **Mehrstoffbrenner Kerosin und Öl/Gas**
- E** **Quemador policombustible queroseno y gasóleo/gas**

Funzionamento bistadio progressivo o modulante  
Two stage progressive or modulating operation  
Fonctionnement à 2 allures progressif ou modulant  
Zweistufig gleitender oder modulierender Betrieb  
Funcionamiento a dos llamas progresivas o modulante

<b>CODICE - CODE CÓDIGO</b>	<b>MODELLO - MODEL - MODELE MODELL - MODELO</b>	<b>TIPO - TYPE - TYP</b>
20034251	RLS 650/M MX	1310 T

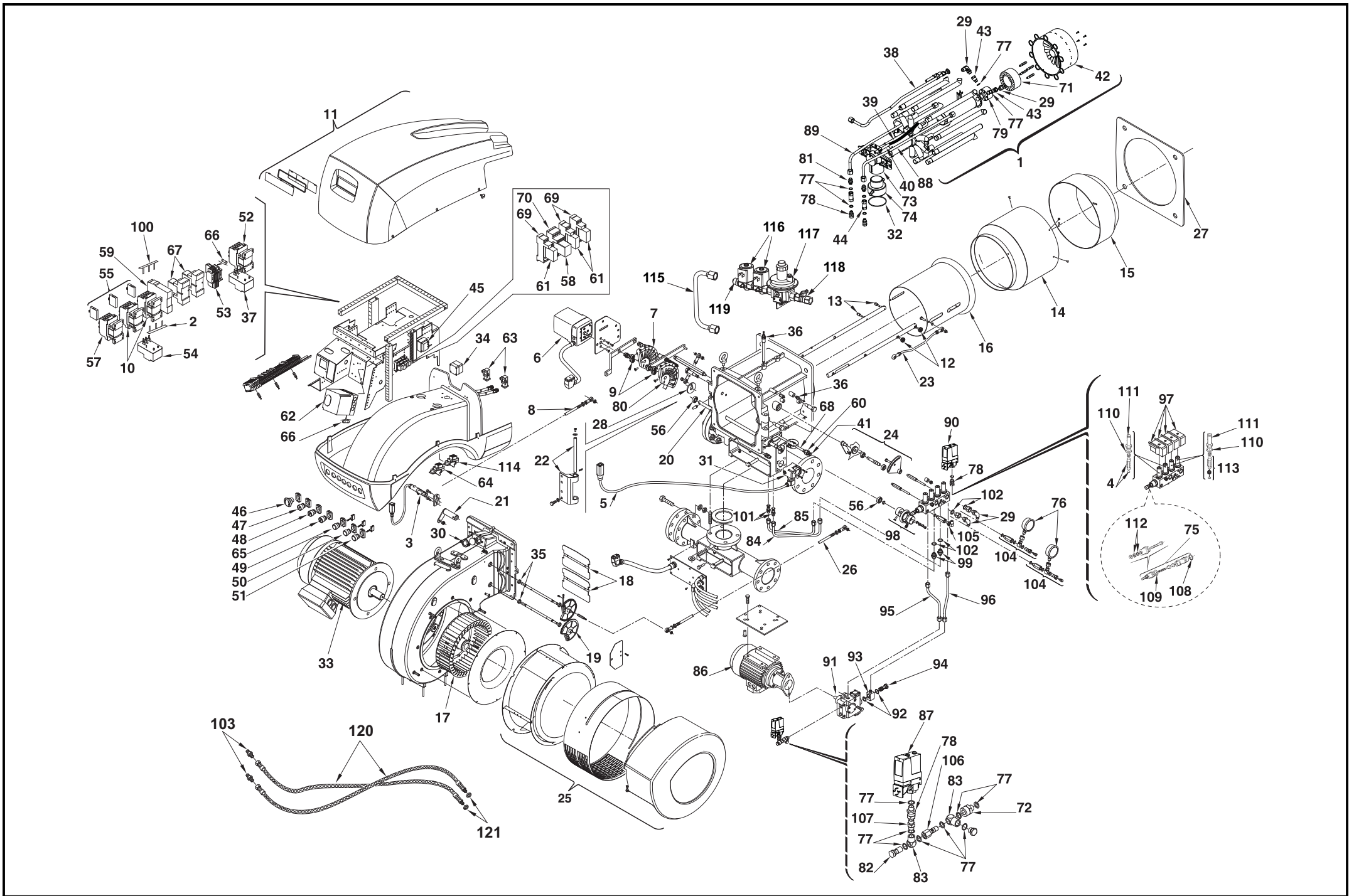

N.	COD.	DESCRIZIONE	DESCRIPTION	DESCRIPTION	BESCHREIBUNG	DENOMINACION	MATRICOLA BRUCIATORE BURNER SERIAL NUMBER MATRICULE BRULEUR BRENNER KENN-NUMMER MATRICULA QUEMADORES	*
1	20026758	GRUPPO TESTA DI COMBUSTIONE	COMBUSTION HEAD ASSEMBLY	GROUPE TÊTE DE COMBUSTION	VERBRENNUNGSKOPFSYSTEM	GRUPO CABEZAL DE COMBUSTIÓN		
2	20005522	CONNESSIONI STELLA / TRIANGOLO	STAR / DELTA POWERED CONNECTIONS	CONNEXIONS ÉTOILE / TRIANGLE	STERN / DREIECK VERBINDUNGEN	CONEXIONES ESTRELLA / TRIÁNGULO		
3	20005518	FOTOCPELLULA UV	UV CELL	PHOTOCPELLULE UV	UV PHOTOZELLE	FOTORESISTENCIA UV		A
4	3014198	NUCLEO	CORE	NOYAU	KERN	NÚCLEO		
5	3013303	COLLEGAMENTO PRESSOSTATO	PRESSURE SWITCH CONNECTION	CONNEXION PRESSOSTAT	DRUCKWÄCHTER VERBINDUNG	CABLES PRESOSTATO		C
6	20005519	SERVOMOTORE	SERVOMOTOR	SERVOMOTEUR	STELLMOTOR	SERVOMOTOR		B
7	3013865	CAMMA ARIA	AIR CAM	AIR CAME	LUFT-NOCKEN	EXCÉNTRICO AIRE		C
8	3013651	TIRANTE	TIE ROD	TIRANT	GESTÄNGE	TIRANTE		C
9	3013652	PERNO	SCREW	VIS CREUSE	HOHLKERNSCHRAUBE	JUNTA		C
10	3013978	CONTATTORE	CONTACTOR	CONTACTEUR	SCHÜTZ	CONTACTOR		C
11	3013310	COFANO	COVER	COFFRET	VERKLEIDUNG	ENVOLENTE		
12	3013965	PERNO	SCREW	VIS CREUSE	HOHLKERNSCHRAUBE	JUNTA	≤ 02241005417	C
12	20038376	PERNO	SCREW	VIS CREUSE	HOHLKERNSCHRAUBE	JUNTA	≥ 02241005418	C
13	3013964	PERNO	SCREW	VIS CREUSE	HOHLKERNSCHRAUBE	JUNTA	≤ 02241005417	C
13	20038375	PERNO	SCREW	VIS CREUSE	HOHLKERNSCHRAUBE	JUNTA	≥ 02241005418	C
14	20026703	CILINDRO	SLEEVE	CYLINDRE	ZYLINDER	CILINDRO		
15	20026702	IMBUTO FIAMMA	END CONE	EMBOUT GUEULARD	FLAMMENROHR	TUBO EXTREMO		B
16	20026704	OTTURATORE	SHUTTER	OBTURATEUR	SCHIEBER	OBTURADOR	≤ 02241005417	C
16	20038374	OTTURATORE	SHUTTER	OBTURATEUR	SCHIEBER	OBTURADOR	≥ 02241005418	C
17	3013962	GIRANTE	FAN	TURBINE	GEBLÄSERAD	TURBINA		C
18	3013319	SERRANDA ARIA	AIR DAMPER	VOLET	AIRLUFTKLAPPE	REGISTRO AIRE		
19	3013320	INGRANAGGIO	GEAR TRAIN	EN GRENAGE	RÄDERPAAR	ENGRANAJE		
20	20011096	ALBERO	SHAFT	PIVOT	NOCKEN	EJE		C
21	3013971	LEVA	LEVER	LEVIER	HEBEL	PALANCA		C
22	3013960	CERNIERA	HINGE	CHARNIERE	SCHARNIER	BISAGRA		
23	3013324	TIRANTE INTERNO	INTERNAL TIE ROD	TIRANT INTERIEUR	INNERES GESTÄNGE	TIRANTE INTERNO		C
24	20011097	GRUPPO LEVE	LEVER ASSEMBLY	GROUPE LEVIER	HEBEL	GRUPO LEVAS	≤ 02241005417	
24	20041341	GRUPPO LEVE	LEVER ASSEMBLY	GROUPE LEVIER	HEBEL	GRUPO LEVAS	≥ 02241005418	
25	3013326	GRUPPO ASPIRAZIONE	AIR INTAKE ASSEMBLY	GROUPE ASPIRATION	ANSAUGGRUPPE	GRUPO ASPIRACION		
26	3013327	TIRANTE ESTERNO	EXTERNAL TIE ROD	TIRANT EXTERIEUR	AUSSERES GESTÄNGE	TIRANTE ESTERNO		C
27	20011117	SCHERMO	FLANGE GASKET	ECRAN THERMIQUE	FLANSCHDICHTUNG	JUNTA AISLANTE		A
28	3014195	QUADRANTE	SCALE LEVER	LEVIER DE BALANCE	SKALAHEBEL	PALANCA DE LA ESCALA		
29	20011202	RACCORDO	CONNECTOR	MAMELON	NIPPEL	RACORD		C
30	3008663	VETRINO	VIEWING PORT	REGARD	SCHAUGLAS	PLATINA		C
31	3012197	PRESSOSTATO GAS	GAS PRESSURE SWITCH	PRESSOSTAT GAZ	GASDRUCKWÄCHTER	PRESOSTATO GAS		B
32	3007002	O-RING	O-RING	JOINT TORIQUE	O-RING	JUNTA TÓRICA		B
33	20026757	MOTORE	MOTOR	MOTEUR	MOTOR	MOTOR		C
34	3013449	PRESSOSTATO ARIA	AIR PRESSURE SWITCH	PRESSOSTAT AIR	LUFTDRUCKWÄCHTER	PRESOSTATO DEL AIRE		A
35	3012795	CUSCINETTO	BEARING	ROULEMENT	LAGER	COJINETE		C
36	3005447	PRESA DI PRESSIONE	PRESSURE TEST POINT	PRISE DE PRESSION	DRUCKENTNAHMESTELLE	TOMA DE PRESIÓN		C
37	20005527	RELÈ TERMICO	OVERLOAD	RELAIS THERMIQUE	ÜBERSTROMAUSLÖSER	RELÈ TERMICO		C

N.	COD.	DESCRIZIONE	DESCRIPTION	DESCRIPTION	BESCHREIBUNG	DENOMINACION	MATRICOLA BRUCIATORE BURNER SERIAL NUMBER MATRICULE BRULEUR BRENNER KENN-NUMMER MATRICULA QUEMADORES	*
38	20011118	GRUPPO PILOTA DI ACCENSIONE	IGNITION PILOT ASSEMBLY	GROUPE PILOTE D'ALLUM-AGE	ZÜNDPILOTIERUNGSSYSTEM	GRUPO PILOTO DE ENCEN-DIDO		
39	3012282	COLLEGAMENTO ELETTRODO	HIGH VOLTAGE LEAD	CONNEXION ELECTRODE	VERBINDUNG ELEKTRODE	CABLE ELECTRODO		A
40	3012258	ISOLATORE	INSULATOR	PORCELAINE D'ELECTRODE	ISOLATOR	AISLADOR		A
41	3007029	O-RING	O-RING	JOINT TORIQUE	O-RING	JUNTA TÓRICA		B
42	20011119	ELICA	DISC HOLDER	SUPPORT DE L'ACCROCHE FLAMME	STAUSCHEIBENHALTERUNG	SOPORTE ESTABILIZADOR		A
43	20011120	RACCORDO	CONNECTOR	MAMELON	NIPPEL	RACORD		C
44	20011122	VALVOLA NON RITORNO	VALVE NOT RETURN	VANNE PAS RETOUR	RÜCKSCHLAGVENTIL	VALVOLA NO DE VUELTA		B
45	3003847	TRASFORMATORE	TRANSFORMER	TRANSFORMATEUR	ZÜNDTRANSFORMATOR	TRANSFORMADOR		B
46	3013333	PULSANTE EMERGENZA	EMERGENCY PUSH-BUTTON	BOUTON ARRÊT D'URGENCE	NOTSTOPTASTE	BOTÓN DE EMERGENCIA		C
47	3013334	SELETTORE AUTO/MAN	SWITCH AUTO/MAN	SÉLECTEUR AUTO/MAN	SCHALTER AUTO/MAN	SELECTIVO AUTO/MAN		C
48	3013335	SELETTORE + / -	SWITCH + / -	SÉLECTEUR + / -	SCHALTER + / -	SELECTIVO + / -		C
49	3013366	INDICATORE LUMINOSO VERDE	GREEN SIGNAL LIGHT	SIGNAL LUMINEUX VER	GRÜNE LEUCHTANZEIGE	INDIC. LUMINOSO VERDE		A
50	3013353	INDICATORE LUMINOSO ROSSO	RED SIGNAL LIGHT	SIGNAL LUMINEUX ROUGE	ROTE LEUCHTANZEIGE	INDIC. LUMINOSO ROJO		A
51	3013354	PULSANTE LUMINOSO ROSSO DI RESET	RED RESET PUSH-BUTTON	BOUTON ROUGE DE RESET	ROTER KNOPF FÜR RESET	BOTÓN LUMINOSO ROJO DE RESET		C
52	20005525	CONTATTORE	CONTACTOR	CONTACTEUR	SCHÜTZ	CONTACTOR		C
53	3013359	MORSETTIERA AUSILIARIA	AUXILIARY TERMINAL STRIP	PLAQUE À BORNES AUXILIAIRE	HILFSKLEMMENBRETT	REGLETA CONEXIONES AUXILIARIA		
54	20005524	RELÈ TERMICO	OVERLOAD	RELAIS TERMIQUE	ÜBERSTROMAUSLÖSER	RELÉ TÉERMICO		C
55	3012783	CONTATTO AUSILIARIO	AUXILIARY CONTACT	CONTACTES AUXILIAIRE	HILFSKONTAKT	CONTACTO AUXILIAR		B
56	3013650	CUSCINETTO	BEARING	ROULEMENT	LAGER	COJINETE		C
57	3013979	CONTATTORE	CONTACTOR	CONTACTEUR	SCHÜTZ	CONTACTOR		C
58	3012368	RELÈ	RELAY	RELAIS	RELAIS	RELÉ		
59	3012785	TEMPORIZZATORE	TIMER	TEMPORISATEUR	ZEITRELAIS	RETARDATOR		B
60	3013653	RACCORDO	CONNECTOR	MAMELON	NIPPEL	RACORD		C
61	3012842	RELÈ	RELAY	RELAIS	RELAIS	RELÉ		C
62	3006090	APPARECCHIATURA	CONTROL BOX	BOITE DE CONTROLE	STEUERGERÄT	CAJA CONTROL		B
63	3013363	PRESA 7 POLI 90°	7 POLE SOCKET 90°	PRISE À 7 PÔLES 90°	7-POLIGE STECKDOSE 90°	CONECTOR HEMBRA DE 7 CONTACTOS 90°		
64	3013364	PRESA 17 POLI	17 POLE SOCKET	PRISE À 17 PÔLES	17-POLIGE STECKDOSE	CONECTOR HEMBRA DE 17 CONTACTOS		
65	3013474	SELETTORE GAS/OLIO	SWITCH GAS/OIL	SÉLECTOR GAZ/OIL	SCHALTER GAS/ÖL	SELECTIVO GAS/OLEO		C
66	3014106	FUSIBILE 6,3 A	FUSE 6.3 A	FUSIBLE 6,3 A	SCHMELZSICHERUNG 6,3 A	FUSIBLE 6,3 A		
67	20005520	RELÈ + ZOCCOLO	RELAY + BASE	RELAIS + SOCLE	RELAIS + SOCKEL	RELÉ + ZOCALO		
68	20011146	ALBERO	SHAFT	PIVOT	NOCKEN	EJE		C
69	3012841	ZOCCOLO	BASE	SOCLE	SOCKEL	ZOCALO		C
70	3003935	ZOCCOLO	BASE	SOCLE	SOCKEL	ZOCALO		C
71	20011151	TAZZA	AIR DIFFUSER	DIFFUSEUR D'AIR	STAUSCHEIBE	DIFUSOR DEL AIRE		C
72	3008571	RACCORDO	CONNECTOR	MAMELON	NIPPEL	RACORD		C
73	3014118	GOMITO	ELBOW	COUDE	GASSCHLITTEN	CODO		
74	3014116	VOLANTINO	CONTROL WHEEL	ROUE DE CONTROLE	REGELRAD	RUEDA DE CONTROL		

N.	COD.	DESCRIZIONE	DESCRIPTION	DESCRIPTION	BESCHREIBUNG	DENOMINACION	MATRICOLA BRUCIATORE BURNER SERIAL NUMBER MATRICULE BRULEUR BRENNER KENN-NUMMER MATRICULA QUEMADORES	*
75	3014173	GRUPPO REGOLATORE	REGULATOR	GROUPE RÉGULATEUR	REGLERGRUPPE	CONJUNTO REGULADOR		
76	3006140	MANOMETRO	GAUGE	MANOMÈTRE	DRUCKMESSER	MANÓMETRO		
77	3007166	GUARNIZIONE	GASKET	JOINT	DICHTUNG	JUNTA		
78	20011190	RACCORDO	CONNECTOR	MAMELON	NIPPEL	RACORD		
79	20011191	POLVERIZZATORE	SPRAY NOZZLE	BUSE D'INJECTION GICLEUR	EINSPRITZDÜSE	PULVERIZADOR		
80	3012864	CAMMA GAS	GAS CAM	GAZ CAME	GAS-NOCKEN	EXCÉNTRICO GAS		
81	20011192	RACCORDO	CONNECTOR	MAMELON	NIPPEL	RACORD		C
82	3003006	PERNO	SCREW	VIS CREUSE	HOHLKERNSCHRAUBE	JUNTA		C
83	3012455	RACCORDO	CONNECTOR	MAMELON	NIPPEL	RACORD		C
84	20011193	TUBO	PIPE	TUYAU	ROHR	TUBO		
85	20011195	TUBO	PIPE	TUYAU	ROHR	TUBO		
86	3012283	MOTORE POMPA	PUMP MOTOR	MOTEUR POMPE	PUMPENMOTOR	MOTOR BOMBA		
87	20054916	PRESSOSTATO OLIO MIN.	MIN. OIL PRESSURE SWITCH	PRESSOSTAT HUILE MIN.	MIN. ÖLDRUCKWÄCHTER	PRESOSTATO ACEITE PARA MÍNIMA		
88	20011196	TUBO	PIPE	TUYAU	ROHR	TUBO		
89	20011197	TUBO	PIPE	TUYAU	ROHR	TUBO		
90	20054917	PRESSOSTATO OLIO MAX.	MAX. OIL PRESSURE SWITCH	PRESSOSTAT HUILE MAX.	MAX. ÖLDRUCKWÄCHTER	PRESOSTATO ACEITE PARA MÁXIMA		
91	3006410	POMPA	PUMP	POMPE	PUMPE	BOMBA		C
92	3007164	GUARNIZIONE	GASKET	JOINT	DICHTUNG	JUNTA		
93	3003229	RACCORDO	CONNECTOR	MAMELON	NIPPEL	RACORD		C
94	3006184	PERNO	SCREW	VIS CREUSE	HOHLKERNSCHRAUBE	JUNTA		C
95	20011198	TUBO	PIPE	TUYAU	ROHR	TUBO		
96	20011199	TUBO	PIPE	TUYAU	ROHR	TUBO		
97	3003001	BOBINA	COIL	BOBINE	SPULE	BOBINA		
98	3003186	CUSCINETTO	BEARING	PALIER	LAGER	COJINETE		
99	3003240	RACCORDO	CONNECTOR	MAMELON	NIPPEL	RACORD		C
100	20005522	CONNESSIONI STELLA / TRIANGOLO	STAR / DELTA POWERED CONNECTIONS	CONNEXIONS ÉTOILE / TRIANGLE	STERN / DREIECK VERBINDUNGEN	CONEXIONES ESTRELLA / TRIÁNGULO		
101	20011200	RACCORDO	CONNECTOR	MAMELON	NIPPEL	RACORD		C
102	3007082	GUARNIZIONE	GASKET	JOINT	DICHTUNG	JUNTA		
103	3006181	RACCORDO	CONNECTOR	MAMELON	NIPPEL	RACORD		C
104	3013998	RACCORDO	CONNECTOR	MAMELON	NIPPEL	RACORD		C
105	3014179	RACCORDO	CONNECTOR	MAMELON	NIPPEL	RACORD		C
106	20011205	PERNO	SCREW	VIS CREUSE	HOHLKERNSCHRAUBE	JUNTA		C
107	3009046	RACCORDO	CONNECTOR	MAMELON	NIPPEL	RACORD		C
108	3003201	O-RING	O-RING	JOINT TORIQUE	O-RING-DICHTUNG	JUNTA TÓRICA		
109	3003204	O-RING	O-RING	JOINT TORIQUE	O-RING-DICHTUNG	JUNTA TÓRICA		
110	3007081	GUARNIZIONE	GASKET	JOINT	DICHTUNG	JUNTA		
111	3014196	GUAINA	SHEATH	GAINE	HÜLSE	VAINA		
112	3003203	O-RING	O-RING	JOINT TORIQUE	O-RING-DICHTUNG	JUNTA TÓRICA		
113	3014197	NUCLEO	CORE	NOYAU	KERN	NUCLEO		
114	3013473	PRESA 8 POLI	8 POLE SOCKET	PRISE À 8 PÔLES	8-POLIGE STECKDOSE	CONECTOR HEMBRA DE 8 CONTACTOS		C

N.	COD.	DESCRIZIONE	DESCRIPTION	DESCRIPTION	BESCHREIBUNG	DENOMINACION	MATRICOLA BRUCIATORE BURNER SERIAL NUMBER MATRICULE BRULEUR BRENNER KENN-NUMMER MATRICULA QUEMADORES	*
115	20013237	TUBO	TUBE	TUYAU	SCHLAUCH	TUBO		
116	3012853	ELETTROVALVOLA	SOLENOID VALVE	ELECTROVANNE	MAGNETIVENTIL	ELECTROVÁLVULA		B
117	3012653	STABILIZZATORE	STABILIZER	STABILISATEUR	STABILISATOR	ESTABILIZADOR		
118	3012852	RUBINETTO GAS	GAS COCK	ROBINET GAZ	GASHAHN	GRIFO GAS		
119	3003225	RACCORDO	CONNECTOR	MAMELON	NIPPEL	RACORD		C
120	20034085	TUBO FLESSIBILE	HOSE	TUYAU FLEXIBLE	ÖLSCHLAUCH	TUBO FLEXIBLE		A
121	3007164	GUARNIZIONE	SEAL	JOINT	DICHTUNG	JUNTA		B

\*

**RICAMBI CONSIGLIATI - ADVISED PARTS - RECHANGE CONSEIL - EMPFOHLENE ERSATZTEILE - RECAMBIOS ACONSEJADOS**

A = Ricambi per dotazione minima - Spare parts for minimum fittings - Pièces détachées pour équipement minimum - Ersatzteile für minimale Ausstattung - Recambios para equipamiento mínimo

A+B = Ricambi per dotazione base di sicurezza - Spare parts for basic safety fittings - Pièces détachées pour équipement standard de sécurité - Ersatzteile für Sicherheitsgrundausrüstung - Recambios para equipamiento básico de seguridad

A+B+C = Ricambi per dotazione estesa di sicurezza - Spare parts for extended safety fittings - Pièces détachées pour équipement complet de sécurité - Ersatzteile für erweiterte Sicherheitsausstattung - Recambios para equipamiento general de seguridad



---

**RIELLO**

RIELLO S.p.A.  
I-37045 Legnago (VR)  
Tel.: +39.0442.630111  
[http:// www.riello.it](http://www.riello.it)  
[http:// www.rielloburners.com](http://www.rielloburners.com)